



## ActivPanel™ i-Series

INTERACTIVE FLAT PANELS

65" HD, 75" 4K

The ActivPanel i-Series is the essential interactive panel for customers looking to replace their projector-based systems with a long-term, reliable solution. It offers a high-resolution display that is significantly brighter than projector systems and enables flexibility to add on computing and mounting options depending on the schools' technology needs.

# The Essential Interactive Panel for the Classroom

## Simpler and Better Solution for the Classroom



ActivPanel i-Series is easy to use with a single power button and front ports that allow quick connectivity to a teacher's laptop. Its built-in 15-watt, front-facing speakers are perfect for multimedia lessons. Unlike projector systems, there are no more shadows, glare, or a need to close the blinds.

## Lower Total Cost of Ownership



ActivPanel i-Series offers a practically maintenance-free solution. Unlike projector-based systems, there is no instructional time lost or additional costs incurred due to calibration and replacement of bulbs, filters, and the projector.

## Classroom Lesson Delivery Software



Deliver interactive, multimedia lessons offline or online using your choice of Promethean's educational software products. Both ClassFlow™ and ActivInspire™ software are free and come as standard with the ActivPanel. To learn more, visit [PrometheanWorld.com/Software](http://PrometheanWorld.com/Software).



**Full HD to 4K Ultra HD Displays**  
Features crisp details and bright colors

**Infrared Technology**  
Features up to 10 simultaneous touch points

**OPS Slot**  
Select from the Android™ or Windows® Modules to add-on display computing

**Built-In Sound**  
Powerful, dual 15 W front-facing stereo speakers

**Easy Device Connectivity**  
Accessible ports for HDMI® and USB connectivity



Industry-Leading



4K Ultra HD\*



10 Touch Points



Pen and Touch



Anti-Glare Glass



Software Included



Front HDMI and USB Ports



Comprehensive Warranty



Front-Facing Speakers



OS Compatible Devices

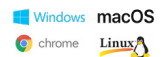

## Flexible Configurations for the Classroom

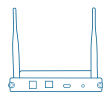

The Android Module is a recommended purchase for a tablet-like experience, with access to the Internet, whiteboard, mirroring, and more. A Windows Module is available for an all-in-one, large-format Windows experience.



Select from versatile mounting\*, including a fixed wall mount, height-adjustable wall mount, height-adjustable mobile stand, and non-adjustable mobile stand.



Enhance your classroom audio with the ActivSoundBar, providing deep bass and room-filling sound.

\*Based on model and region as applicable

ActivPanel i-Series 2018 SS 01/18 v3.2 EN

Page 2

## PRODUCT CODE

|            |                              |
|------------|------------------------------|
| VTP-65     | ActivPanel i-Series (65" HD) |
| VTP2-75-4K | ActivPanel i-Series (75" 4K) |

Note: Regional SKUs may have additional country code suffix

## DISPLAY

|                |  |
|----------------|--|
| Diagonal Size  | Available in 65" HD, 75" 4K  |
| Screen Type    | TFT LCD (Direct LED Backlight)   |
| Aspect Ratio   | 16:9   |
| Display Area   | 65" HD: 1429 x 804 mm (56.2 x 32.6 in)<br>75" 4K: 1650 x 928 mm (65 x 36.5 in) |
| Resolution     | 65" HD (1920 x 1080 px @ 60 Hz)<br>75" 4K (3840 x 2160 px @ 60 Hz)             |
| Response Time  | 8 ms   |
| Refresh Rate   | 60 Hz  |
| Display Colors | 1.07 Billion   |
| Contrast Ratio | 4000:1   |
| Brightness     | 350 cd/m <sup>2</sup> typical  |
| Glass Hardness | 7 Mohs, 9H pencil  |
| Glass Type     | Heat-tempered, Anti-Glare  |
| Freeze Screen  | Yes  |
| Blank Screen   | Yes  |

## CONNECTIVITY

|                 |                                      |
|-----------------|--------------------------------------|
| HDMI In         | x3                                   |
| USB Touch       | x2                                   |
| VGA In          | x1                                   |
| VGA Audio In    | x1                                   |
| YPbPr           | x1                                   |
| CVBS            | x1                                   |
| Mic In (3.5 mm) | x1                                   |
| Headphone       | x1                                   |
| USB 2.0         | x2                                   |
| RS232 Serial    | x1                                   |
| OPS Slot        | x1 (with dedicated front USB 2.0 x2) |

## AUDIO

|          |                              |
|----------|------------------------------|
| Speakers | Front-facing stereo speakers |
| Power    | 2 x 15 W                     |

## POWER

|                             |                               |
|-----------------------------|-------------------------------|
| Power Requirements          | 100V - 240V AC                |
| Power Consumption (Normal)  | 65" HD: 120W; 75" 4K: <= 300W |
| Power Consumption (Standby) | <= 0.5 W                      |

## ENVIRONMENTAL

|                       |                                    |
|-----------------------|------------------------------------|
| Operating Temperature | 0°C to 40°C (32°F to 104°F)        |
| Storage Temperature   | -15°C to 55°C (-5°F to 131°F)      |
| Operating Humidity    | 20% to 80% non-condensing humidity |
| Storage Humidity      | 20% to 90% non-condensing humidity |

## INTERACTIVITY

|                          |  |
|--------------------------|--|
| Continuous Touch Points  | Up to 10   |
| Gestures and Edge Swipes | Windows® Supported   |
| Touch Technology         | Infrared   |
| Touch Resolution         | 32,768 x 32,768 px   |
| Touch Accuracy           | +2 mm  |
| Max Touch Response Time  | 15 ms  |
| Tracking Rate            | 65" HD = 3 m/s; 75" 4K = 5 m/s   |
| Scan Rate                | 65" HD = 6 ms; 75" 4K = 7 ms   |
| Compatibility*           | Windows® 7 to 10<br>OS X® 10.8 to 10.11<br>macOS® Sierra 10.12.1 or later<br>Linux® Ubuntu 16.04 LTS<br>Chrome OS™ |

## PEN

|                  |  |
|------------------|--|
| Pens Included    | x1   |
| Pen Type         | Battery-Less (not differentiated from touch) |
| Pen Holder       | Pen holder attached to ActivPanel            |
| Pen Tip Diameter | 8 mm   |

## PACKED CONTENTS

|                   |  |
|-------------------|--|
| What's in the Box | ActivPanel i-Series x1, Pen x1, Remote control x1, AAA remote batteries x2, Power cable (3m/9.8ft. quantity is SKU dependent), HDMI cable x1 (3m/9.8 ft.), USB cable x1 (3m/9.8 ft.), Quick install guide x1, ClassFlow and ActivInspire Professional included |
|-------------------|--|

## OPTIONAL STANDS & ACCESSORIES

|                                |  |
|--------------------------------|--|
| Fixed Wall Mount (Vesa)        | Available in all markets   |
| Height-Adjustable Wall Mount   | Available in specific markets  |
| Height-Adjustable Mobile Stand | Available in specific markets  |
| Non-Adjustable Mobile Stand    | Available in all markets   |
| ActivSoundBar                  | Add the powerful, high-quality sound bar   |
| Android Module                 | Available in specific markets; Includes Android 6.0 Marshmallow, CPU Realtek RTD1295 Quad Core up to 1.4 GHz, GPU ARM T820, up to 4K @ 60Hz, 2 GB DDR4 RAM, 16 GB Internal Storage   |
| Windows Module                 | Available in specific markets; Intel® Core™ i5 Dual, 8 GB DDR4 RAM, 256 GB SSD, Wi-Fi® 802.11 AC (2x2), 4K @ 60 Hz<br>Two options are available: 1. Windows 10 IoT pre-installed; 2. No operating system installed. Both options include an External Android (ActivConnect G) with pre-loaded software. Minimum order quantity required for both models. |

## PHYSICAL SPECIFICATIONS

|                        |  |
|------------------------|--|
| 65" HD (Without Mount) |  |
| Product Dimensions     | 1544 x 939 x 99 mm (61 x 37 x 3.9 in)      |
| Packed Dimensions      | 1710 x 1350 x 540 mm (67 x 53 x 21 in)     |
| Net Weight             | 45 kg (99.2 lbs)                           |
| Packed Weight          | 57 kg (126 lbs)                            |
| 75" 4K (Without Mount) |  |
| Product Dimensions     | 1768 x 1066 x 114 mm (69.6 x 42 x 4.48 in) |
| Packed Dimensions      | 1918 x 1195 x 280 mm (75.5 x 47 x 11 in)   |
| Net Weight             | 59 kg (130 lbs)                            |
| Packed Weight          | 75.9 kg (167.3 lbs)                        |

\*ActivInspire is a desktop application for Windows, Mac, and Linux operating systems. ClassFlow is a cloud-based application for Chrome, Safari®, and Microsoft Edge/Internet Explorer.

ActivPanel i-Series 2018 SS 01/18 v3.2 EN

## COMPLIANCE & CERTIFICATION

Regulatory Certification CE, FCC, IC, UL, CUL, CB, RCM

## WARRANTY

Standard Warranty Three-Year Warranty (upgrade options available and vary by region). For more information, visit [PrometheanWorld.com/ActivCare](http://PrometheanWorld.com/ActivCare).

## INSTALLATION

The installation of this product should be completed by a qualified installer. Use of components not supplied by Promethean or not meeting minimum specifications may impact performance, safety and warranty. For more information, visit Support. [PrometheanWorld.com](http://PrometheanWorld.com).

## SUPPORT

For all Promethean products, visit [Support.PrometheanWorld.com](http://Support.PrometheanWorld.com).

## TECHNICAL DRAWINGS

65" HD

| REF | DESCRIPTION        | DIMENSION        |
|-----|--------------------|------------------|
| A   | IMAGE DIAGONAL     | 1636.2mm (64.4") |
| B   | IMAGE AREA WIDTH   | 1429.0mm (56.3") |
| C   | IMAGE AREA HEIGHT  | 804.0mm (31.7")  |
| D   | ACTIVE AREA WIDTH  | 1479.5mm (58.2") |
| E   | ACTIVE AREA HEIGHT | 824.5mm (32.5")  |

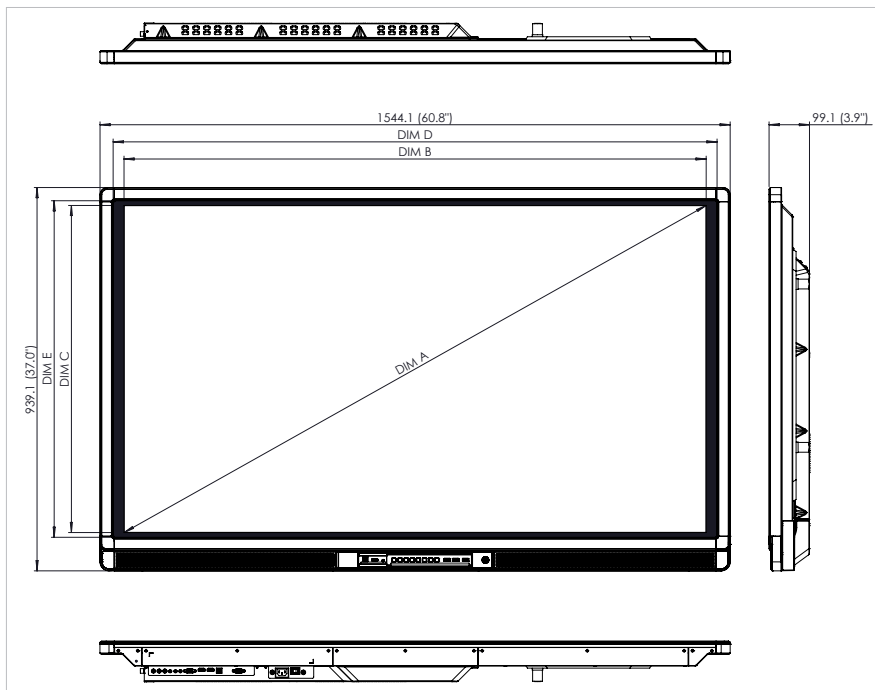

Front

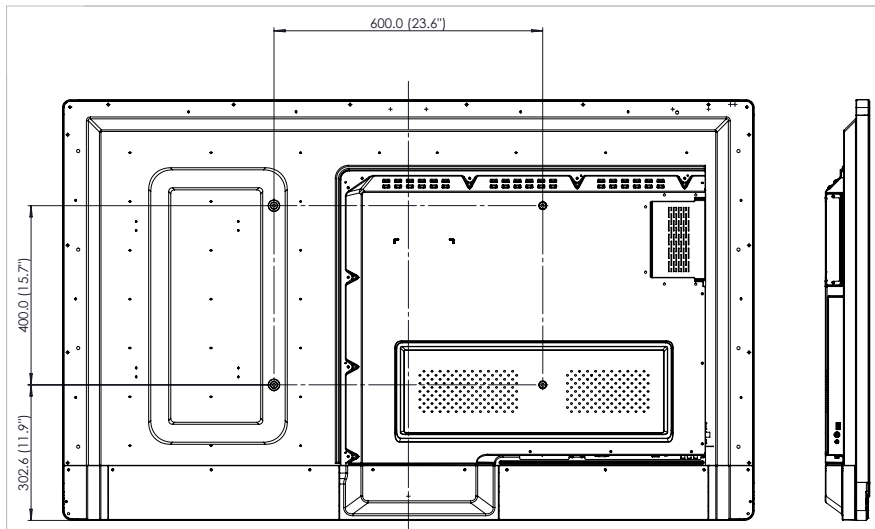

Back

TECHNICAL DRAWINGS

75" 4K

| REF | DESCRIPTION        | DIMENSION        |
|-----|--------------------|------------------|
| A   | IMAGE DIAGONAL     | 1896.1mm [74.7"] |
| B   | IMAGE AREA WIDTH   | 1650.0mm [65.0"] |
| C   | IMAGE AREA HEIGHT  | 928.0mm [36.5"]  |
| D   | ACTIVE AREA WIDTH  | 1703.5mm [67.1"] |
| E   | ACTIVE AREA HEIGHT | 951.5mm [37.5"]  |

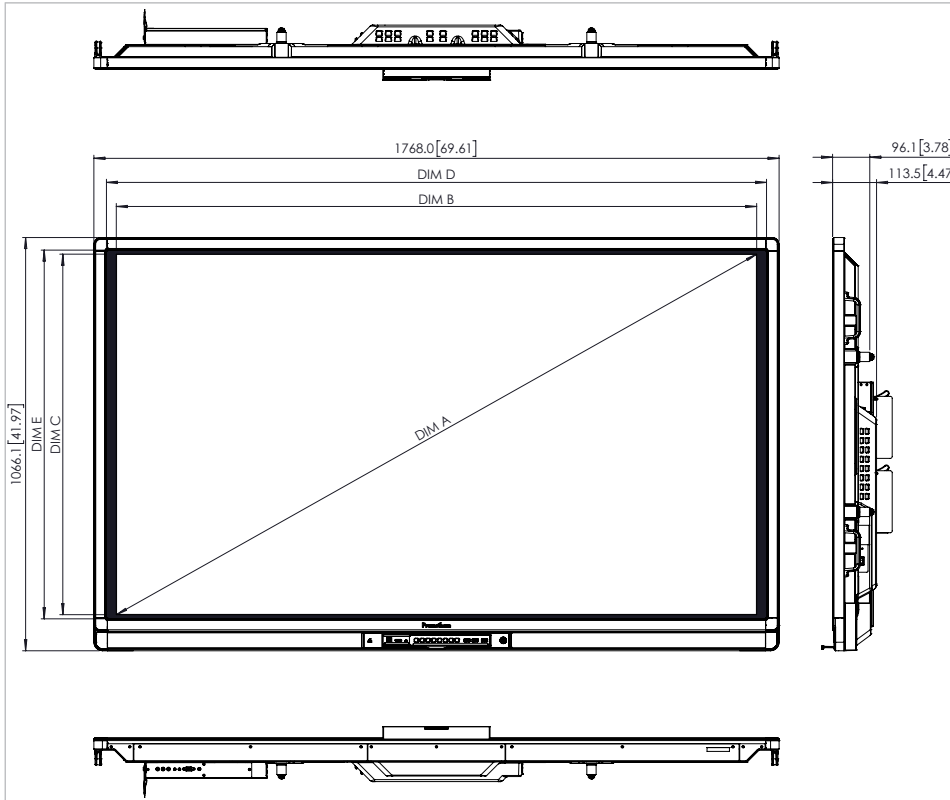

Front

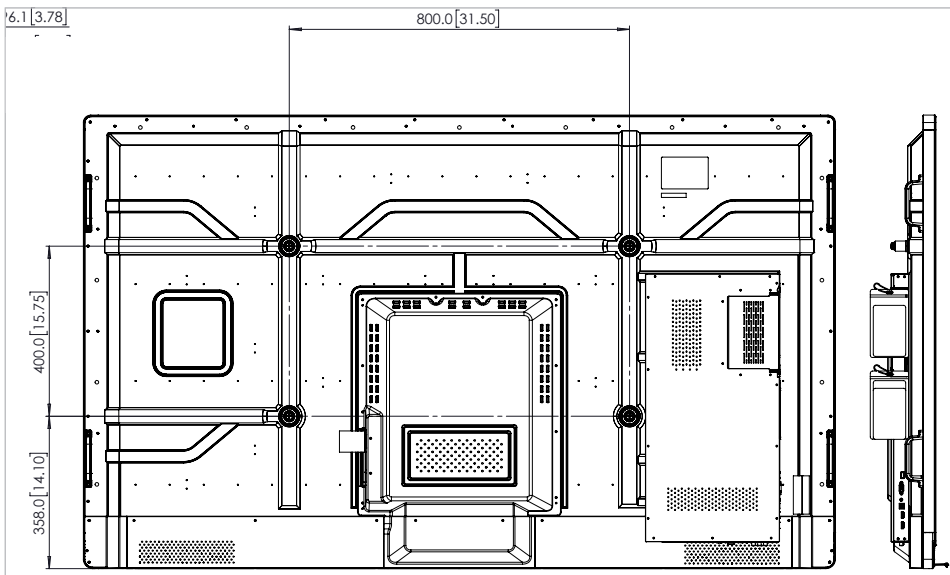

Back

Windows and Microsoft Edge are registered trademarks or trademarks of Microsoft Corporation. All other trademarks are the property of their respective owners. This spec sheet is an independent publication and is neither affiliated with, nor authorized, sponsored, or approved by, Microsoft Corporation.

OS X, macOS and Safari are trademarks of Apple Inc., registered in the U.S. and other countries.

Linux is the registered trademark of Linus Torvalds in the U.S. and other countries.

© 2018 Google LLC, used with permission. Android and Chrome OS are registered trademarks of Google LLC

Wi-Fi is a registered trademark of Wi-Fi Alliance®

Intel and Intel Core are trademarks of Intel Corporation or its subsidiaries in the U.S. and/or other countries.

ActivPanel i-Series 2018 SS 01/18 v3.2 EN